

## CB25 Control Box User Guide



## Introduction

Thank you for choosing the Spectra Precision® Laser CB25. The is used on construction grading machinery to automatically control the blade in earthmoving and grading applications. It is also used on agricultural drainage and land-leveling machinery.

Before using the control box, be sure to read this user guide carefully. Included in it is information about setting up, using, and maintaining the control box. Also included in this manual are **WARNINGS!**, **CAUTIONS**, and **Notes**. Each of these words represents a level of danger or concern. A **WARNING!** indicates a hazard or unsafe practice that *could* result in serious injury or death. A **CAUTION** indicates a hazard or unsafe practice that could result in minor injury or property damage. A **Note** indicates important information unrelated to safety.

Your comments and suggestions are welcome; please contact us at:  
Trimble Construction Division  
5475 Kellenburger Road  
Dayton, Ohio 45424-1099 U.S.A.  
Phone: (937) 245-5600  
(800) 538-7800  
Fax: (937) 233-9004  
Internet: [www.trimble.com](http://www.trimble.com)

Please record your product information below. This will assist you if there are any questions regarding warranty or service.

PRODUCT: \_\_\_\_\_  
SERIAL NUMBER: \_\_\_\_\_  
DATE OF PURCHASE: \_\_\_\_\_  
PURCHASED FROM: \_\_\_\_\_  
PHONE: \_\_\_\_\_

- 2 -

## Access Panel

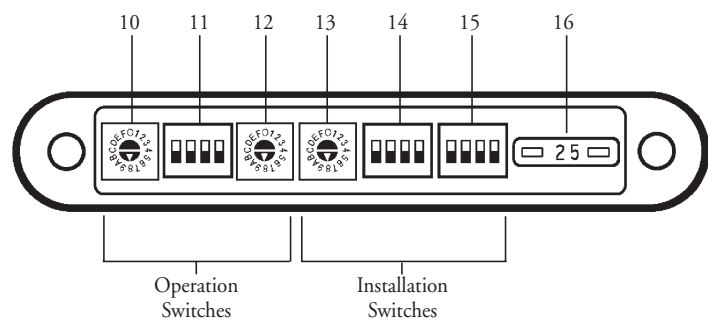

### Operation Switches

- On-Grade Deadband Selection: Rotary Switch (Default setting is "8").
- Performance Selections: Dip Switch 4-Way (Default setting is all in the OFF position).
- Valve Gain (Speed): Rotary Switch: (Default setting is "8").

### Installation Switches

- Valve Balance (Raise/Lower): Rotary Switch
- Valve Setup: Dip Switch 4-Way
- Valve-Drive Selector: Dip Switch 4-Way
- Fuse: 25 Amp

The three left switches (10, 11, and 12) set operating functions. The three right switches (13, 14, and 15) are used during installation for specific valves and machine settings. **These should only be changed by the installation technician.**

- 5 -

## Gain-Selection Switch (12)

The gain-selection rotary switch (12) has sixteen positions. These positions begin with "0" (zero), the slowest reacting, and increase clockwise to "F," the fastest reacting.

When the receiver is in the on-grade deadband, no correction signals are sent to the valve. Immediately after the receiver moves outside of the on-grade deadband, signals are sent to correct the elevation. As the receiver moves further away from the on-grade deadband, the valve continues to open until the valve is in the 100% open state. The distance between this initial opening of the valve and the 100% open state is controlled by the gain.

The default gain setting is "8." Field adjustments may be necessary due to the many variables in the system operation and jobsite requirements. If the system becomes unstable and overreacts between above-grade and below-grade, increase the deadband setting or decrease the gain setting.

## Rear View

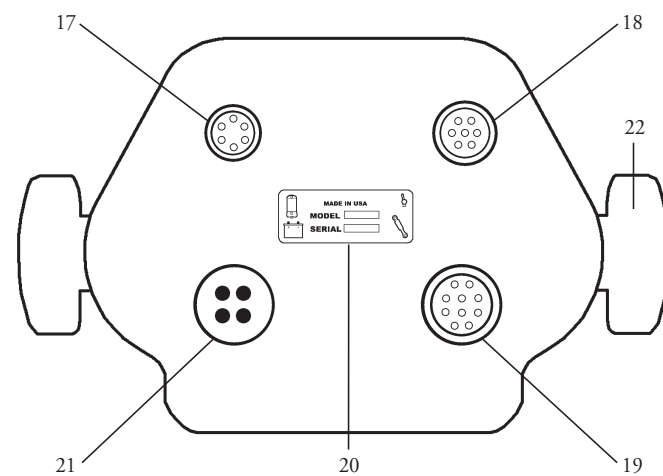

- Receiver Communication: 6-Socket Connector
- Optional Remote Switch: 7-Socket Connector
- Hydraulic Valve Outputs: 10-Socket Connector
- Identification/Serial Number Label
- Machine Power Input: 4-Pin Connector
- Mounting Knobs for Bracket

- 6 -

## Operation

### Power Button

Press the power button once to turn on the system. All LEDs on the box briefly turn on. The red power-on LED stays lit to indicate the power is on. Turning on the box also turns on the receiver. Press the power button again to turn off the system.

### LED Grade Display

When a receiver receives a laser strike, five possible positions of grade information are available. They are as follows:

- High Coarse:* Top 3 red LEDs form down arrow  
*High Fine:* Top 3 red LEDs and 3 green on-grade LEDs  
*On-Grade:* 3 green LEDs form horizontal bar  
*Low Fine:* Bottom 3 red LEDs and 3 green on-grade LEDs  
*Low Coarse:* Bottom 3 red LEDs form up arrow

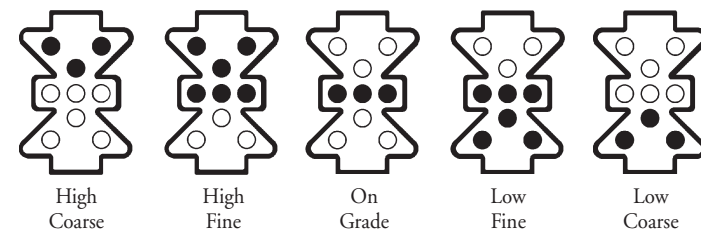

If the receiver moves above or below the laser beam, an out-of-beam is indicated on the LEDs as follows. If the last laser reception was on the bottom of the receiver, the top 3 LEDs flash indicating to move the receiver down. If the last laser reception was on the top, the bottom 3 LEDs flash indicating to move the receiver up. The out-of-beam indication lasts for 2 minutes.

- 9 -

- 10 -

## Safety

Please follow all operating and safety instructions in this guide and that of your machinery.

**WARNING:** Do not remove the back panel of the control box. Only authorized service personnel should access it.

**WARNING:** Be aware of all overhead obstructions and electrical power lines. The receiver and mast may be higher than the machinery. Remove when transporting machinery.

**WARNING:** When working near construction or agricultural machinery, follow all safety precautions as described in the machinery's user guide.

**WARNING:** When excavating, follow all excavation and trench safety regulations and practices.

**CAUTION:** Make sure all equipment is properly installed, the receiver is securely mounted, and all cable connections are tight and secure.

**CAUTION:** The person responsible for the instrument must make sure that it is used in accordance with the instructions. This person is also accountable for training the people who use the instruments and for the safety of the equipment when in use.

**Note:** Environmental Limits—The control box is suitable for use in an atmosphere appropriate for human habitation (no protection in an aggressive or explosive environment). The control box can be used in rain for short periods. Refer to specifications for temperature ranges.

## Maintenance and Care

Your control box may be placed in a protective carrying case. If the control box is transported from job to job inside a protective case and normal instrument precautions are followed, the control box will provide many years of service.

Do not wipe dust or dirt off the control box with a dry cloth as scratching could occur, possibly damaging these surfaces. Use only a good quality cleaner with a soft cloth on all external components. If these surfaces have hardened concrete or other materials on them, take the system to your Authorized Service Center for cleaning.

Inspect the cables daily to make sure that there is no excessive wear, especially at pivot points. Check for crimps or cuts in the wire insulation

- 3 -

## Configuration

The control box is designed to meet different machinery and application requirements. The system operation is a function of deadband setting, gain selection, laser RPM, machine speed, hydraulic pressure and flow, installation settings, and general site or field conditions. The user-selectable settings are the deadband, gain, and LED displays. Two rotary switches are for selecting the on-grade deadband (10) and gain (12), while a dip switch (11) is for selecting the LED grade display. These switches are located in the access panel. To access the switches, turn the 2 thumbscrews counterclockwise and remove the panel from the box housing.

### On-Grade Deadband (Accuracy) Switch (10)

The on-grade deadband switch is a rotary switch (10) that has 16 positions. These deadband-selection positions begin with "0" (zero), the smallest, and increase clockwise to "F," the largest. The table below lists the corresponding on-grade deadband for each switch position. Each number or letter setting represents an increment of approximately 2.5 mm or one-tenth inch (0.10 inch).

	0	1	2	3	4	5	6	7
mm	0	2.5	5.1	7.6	10.2	12.7	15.2	17.8
in.	0	0.1	0.2	0.3	0.4	0.5	0.6	0.7

	8	9	A	B	C	D	E	F
mm	20.3	22.9	25.4	27.9	30.5	33.0	35.6	38.1
in.	0.8	0.9	1.0	1.1	1.2	1.3	1.4	1.5

### Examples:

The deadband setting of "5" would correspond to 12.7 mm (0.5 in.).

The deadband setting of "A" would correspond to 25.4 mm (1.0 in.).

The default on-grade deadband is set to "8" or 20.3 mm (0.8 in.).

- 7 -

## Automatic/Manual Toggle Switch

**Automatic:** From the neutral position, push the toggle switch up for automatic mode (indicated by an "A"). The switch returns to the neutral position. The green LED turns on to confirm that the box is in automatic mode. When the receiver receives a laser strike, the box sends the appropriate signals to the valve to raise or lower the implement to obtain and maintain an on-grade position. If the receiver is not receiving a laser strike, it needs to be moved within the reception range to begin corrections.

**Manual:** From the neutral position, push the toggle switch down for manual mode (indicated by an "M"). The switch returns to the neutral position. The amber LED turns on to confirm that the box is in manual mode. When the receiver receives a laser strike, the box displays the grade information on the LEDs but does not send signals to the valve. Instead, you need to use the raise/lower toggle switch, the optional remote raise/lower switch, or the machine lever to raise or lower the implement.

### Raise/Lower Toggle Switch

This switch raises or lowers the implement. When the system is in manual mode, the raise/lower switch acts just like the manual lever. To raise the implement, push the switch up. To lower the implement, push the switch down. When released, the switch goes back to the neutral position. When the system is in automatic mode, the manual raise/lower switch overrides the automatic setting and raises and lowers the implement. When it is released, the automatic mode resumes normal operation.

## Controls and Displays

### Front View

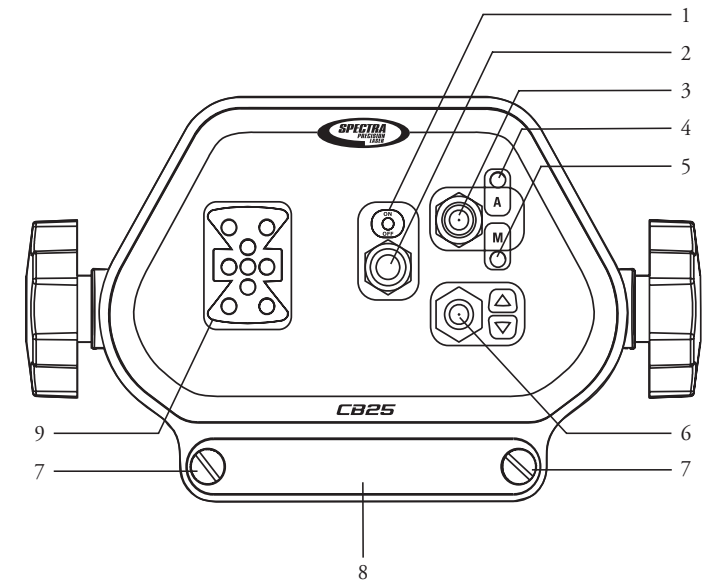

- Power Status LED
- Power Button
- Automatic/Manual Mode Toggle
- Automatic Mode LED
- Manual Mode LED
- Raise/Lower Toggle
- Access Panel Thumbscrews
- Access Panel
- LED Grade Display

- 4 -

## Performance Switch (11) Settings

The dip switch panel consists of 4 individual switches. The up position is ON and the down position is OFF. The function and factory-default setting for each switch are as follows:

Switch #	Function	Position	Default Position
1	Laser strike averaging off	OFF	OFF
	Laser strike averaging on	ON	
2	Receiver LEDs disabled	OFF	OFF
	Receiver LEDs disabled	ON	
3	Control Box LEDs bright	OFF	OFF
	Control Box LEDs dim	ON	
4	Linear Gain	OFF	OFF
	Exponential Gain	ON	

- Laser strike averaging:** This switch is normally in the OFF position. It is turned ON only when required for long range applications where the rotating laser may be relatively unstable due to environmental or jobsite conditions.
- Receiver LED disable:** The receiver LEDs display when the switch is in the default OFF position. No display is on the receiver LEDs when the switch is in the ON position.
- Control Box LEDs:** The default OFF position and normal operating setting for the control box is LEDs "bright." The control box LEDs can be set to dim by changing this switch to the ON position. This may be preferred at night or in low light conditions.
- Linear or exponential gain:** This setting for this switch usually depends on the characteristics of the spool in the hydraulic valve. Do not change this setting without consulting the installation technician.

- 8 -

## System Wiring

All cables should be properly installed. They should be attached to the machine every .6 to 1.0 meter (2 to 3 feet) or less to eliminate cable movement and possible abrasion damage. Special care should be taken at flex points to make sure the cable moves freely and does not rub on other hoses, fittings, or the machine. Provide for adequate cable length to avoid pinching, stretching, and tight bending. Also, cables should not be clamped to pipes or hoses that will be exposed to high temperatures.

- Connect the 4-socket connector on the power cable to the 4-pin connector on the box, and connect the terminal ends to the machine's battery. The red terminal is for the positive post and the black is for ground. The box has reverse polarity protection in case the terminals are incorrectly connected.
- Connect the 6-pin receiver cable end to the 6-socket connector on the box. Connect the 7-socket receiver cable end to the 7-pin connector on the bottom of the receiver. If a coil cord and junction box are used, ensure the proper connections at the junction box.
- Connect the 10-pin valve cable to the 10-socket connector on the box, and connect the open-ended wires to the valve following the directions for the valve.

### Optional Remote Switch

- Attach the switch end at a convenient location, usually on the existing raise lower lever.
- Route the cable to avoid any damage.
- Connect the 7-pin remote switch connector to the 7-socket connector on the box.

**Note:** The remote switch is configured to operate the same as on the control box—the up position is automatic, and the down position is manual. The switch also has the option for raise/lower switch. If installed, raise is the up position and lower is the down position.

- 12 -

- 11 -

## Cable Configurations

Receiver Cable: powers the receiver and communicates grade information between the receiver and the control box.

RECEIVER CABLE			
Function	Control Box	Receiver	Wire
	6 Socket	7 Socket	Color
Power	A	A	Red
Communication	B	B	Green
Communication	C	C	White
Ground (Signal)	D	D	Black
High Power Return	E	E	N/C
High Power Supply	F	F	N/C
	N/A	G	N/C

Power Cable: supplies power to the system. The control box supports both 12- and 24-volt machine systems.

POWER CABLE		
Function	Control Box	Wire
	4 Pin	Color
Machine Ground	A	Black
Machine Ground	B	Black
Machine Power	C	Red
Machine Power	D	Red

- 13 -

## Specifications

On-Grade LEDs	Green
High/Low LEDs	Red
Operating Voltage	10 Volts to 30 Volts DC, Reverse Polarity Protected
Electrical Connection	Standard Military Type
Valve Compatibility	Proportional Time (On/Off), Proportional Current, and, Proportional Voltage
Maximum Current	5 Amps per Coil
Remote Switch Option	Raise/Lower, Auto/Manual Toggle Switches
Weight	2.25 kg (5 lb)
Dimensions	178 mm x 134 mm x 120 mm (7.0 in. x 5.3 in. x 4.8 in.)

- 17 -

## Notes:

Remote-Switch Cable: is an optional accessory that extends the raise/lower and auto/manual switches via a cable.

REMOTE SWITCH CABLE		
Function	Control Box	Wire
	7 Socket	Color
Auto/Manual	A	Orange
Raise/Lower	B	Green
Aux. Remote 0	C	N/C
Aux. Remote 1	D	N/C
N/C	E	N/C
Remote Switch Power	F	Red
Remote Switch Ground	G	Black

Valve Cable: communicates grade information between the control box and the hydraulic valve.

Note: PT = Proportional Time Valve (aka on/off, bang-bang)  
PC = Proportional Current Valve (aka PWM, direct operating current driven)  
PV = Proportional Voltage Valve (aka Danfoss proportional)

VALVE CABLE – Proportional Current/Time			
Function	Function	Control Box	Wire
PV Valve	PC/PT Valve	10 Socket	Color
Not Used	Lower Valve	A	Blue
D.F. Diagnostic	Raise Valve	B	Green
Switched Power	Switched Power	C	Red
Load Sense	Load Sense	D	Orange
PV Signal	Not Used	E	White
		F	N/C
		G	N/C
		H	N/C
Ground	Ground	I	Black
Ground	Ground	J	White/Black

- 14 -

## Declaration of Conformity

We herewith declare, in exclusive responsibility, that the receiver was developed, designed, and manufactured to conform to the Council Directive 89/336/EEC (Electromagnetic Compatibility) including their amendments.

Equipment Type / Environment: Measurement, Control, and Laboratory Equipment

The following harmonized standards were applied:

EN61326: 1997 +A1: 1998 + A2: 2001

Electromagnetic compatibility (EMC)

Requirement for electrical equipment for measurement, control and laboratory use

EN61000-3-2: 2000

Mains Harmonic Emissions

Single Phase < 16A / Phase

EN61000-3-3: 1995 +A1: 2001

Mains Voltage Fluctuations and Flicker Emissions

Single Phase < 16A / Phase

We hereby declare that the equipment specified above conforms to the above Directive(s).

Trimble Navigation Ltd.

5475 Kellenburger Road

Dayton, OH 45424-1099 U.S.A.

July 23, 2004

- 18 -

## Notes:

## Installation

The receiver mounts to round masts from sizes 42 mm to 50 mm O.D. (1.66 in. to 2.00 in.) and to 38 mm (1.5 in.) square tube.

The model STM shock-mounted telescoping mast is ideally suited for machine control applications. The mast allows the receiver to be positioned above the machinery for unobstructed laser reception. The mast has a 1.2 m (4-foot) telescoping adjustment range with an imperial/metric scale for positioning at known elevations. Built-in shock mounts on all four sides provide excellent damping of the laser receiver in rough operating conditions.

**WARNING:** Follow all safety precautions as discussed in the machine's user guide. Also follow all excavation and safety requirements and practices.

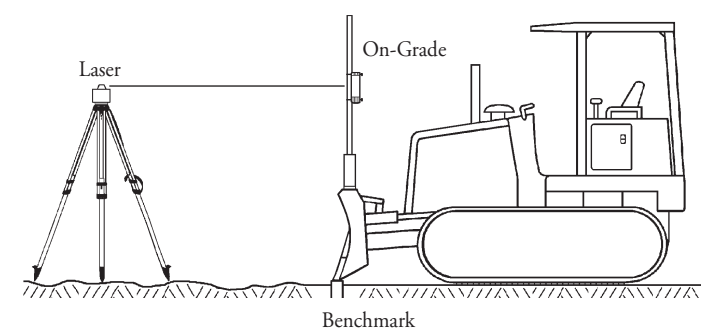

- 15 -

## Warranty

Trimble warrants the receiver to be free of defects in material and workmanship for a period of two years.

Trimble or its authorized service center will repair or replace, at its option, any defective part for which notice has been given during the warranty period. If required, travel and per diem expenses to and from the place where repairs are made will be charged to the customer at the prevailing rates.

Customers should send the product to the nearest authorized service center for warranty repairs, freight prepaid. In countries with Trimble subsidiary service centers, the repaired product will be returned to the customer, freight prepaid.

Any evidence of negligent, abnormal use, accident, or any attempt to repair the product by other than factory-authorized personnel using Trimble certified or recommended parts, automatically voids the warranty.

The foregoing states the entire liability of Trimble regarding the purchase and use of its equipment. Trimble will not be held responsible for any consequential loss or damage of any kind.

This warranty is in lieu of all other warranties, except as set forth above, including any implied warranty merchantability of fitness for a particular purpose, are hereby disclaimed. This warranty is in lieu of all other warranties, expressed or implied.

- 19 -

## Notes:

1. Set up the laser in an appropriate location for receiver visibility and efficient machine operation. Turn on the laser.
2. Position the machine so the blade is set to the desired finished elevation, typically on a benchmark or hub stake.
3. Mount the receiver to the mast.
4. Turn on the system and choose a narrow on-grade deadband for setup (rotary switch, position 1 or 2). Always note the previous setting before making any changes.
5. Slide the receiver up or down until on-grade is indicated. It may be necessary to adjust the height of the laser.
6. Reset the on-grade deadband to the desired accuracy.
7. Face the LED display toward the machine and tighten the clamps.

- 16 -

## Notice to Our European Union Customers

For product recycling instructions and more information, please go to: [www.trimble.com/environment/summary.html](http://www.trimble.com/environment/summary.html)

### Recycling in Europe

To recycle Trimble WEEE, call: +31 497 53 2430, and ask for the "WEEE associate," or

mail a request for recycling instructions to:  
Trimble Europe BV  
c/o Menlo Worldwide Logistics  
Meerheide 45  
5521 DZ Eersel, NL

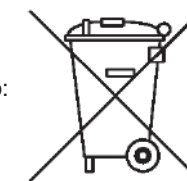

- 20 -

- 21 -

- 22 -

- 23 -



Trimble Construction Division  
5475 Kellenburger Road  
Dayton, Ohio 45424-1099  
U.S.A.  
+1-937-245-5600 Phone  
[www.trimble.com](http://www.trimble.com)

© 2005, Trimble Navigation Limited. All rights reserved.  
Reorder PN 0312-0170 (12/05)

